

## OLED 4 Pin 128x64 Display Module 0.96" Blue Color

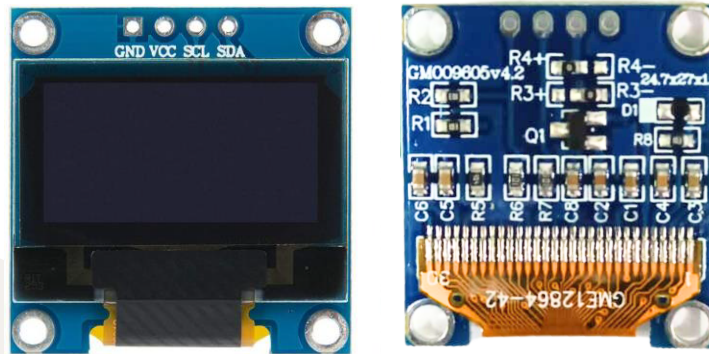

In contrast to LCD technology, Organic Light-Emitting Diode (OLED) displays do not require a backlight and are regarded as the ultimate technology for the next generation of flat-panel displays.

OLED displays are composed of a thin, multi-layered organic film placed between an anode and cathode, which are made up of electric conductive transparent Indium Tin Oxide.

The multi-layered organic film includes a Hole Transporting Layer, Emission Layer and Electron Transporting Layer.

By applying an appropriate electrical voltage, the holes and electrons are injected into the Emission Layer from the anode and cathode respectively and combine to form excitons, after which electroluminescence occurs.

This 0.96" 128\*64 Blue OLED Module offers 128\*64-pixel resolution. They are featuring much less thickness than LCD Displays with good brightness and produce better and true colors.

This OLED Display Module is very compact and will add a great ever user interface experience to your Arduino project. The connection of this display with Arduino is made through the I2C (also called as IIC) serial interface.

The 0.96" 4 pin 128\*64 Blue OLED Display Module produces blue text on black background with very good contrast when supplied with 3.3V-5V Supply. The OLED Display Modules also offers a very wide viewing angle.

### FEATURES:

- Supply voltage: 3.3V-5V
- Pixel: 128\*64
- Display size- 0.96 inch
- Operating temperature range: -40°C - +80°C
- Use I2C Interface
- Chip No: SSD1306
- Color: Blue
- Drive Duty: 1/64 Duty
- Only need 2 I/O port to control

- Supported platforms: For Arduino,51 series, MSP430 series, STIM32/2, SCR chips
- Super high contrast and brightness(adjustable)
- Low power consumption
- High contrast, thus supporting clear display with no need of backlight
- For OLED SSD1306, a more elaborate and beautiful screen than LCD with more functions

**PIN DESCRIPTION:**

Pin No.	Pin Name	Description
1.	Supply Voltage ( Vcc, 5V)	Can be powered by either 3.3V or 5V
2.	Ground (GND)	Pin Ground
3.	Serial Clock(SCL)	Pin SCL of I2C interface
4.	Serial Data(SDA)	Pin SDA of I2C interface

**MECHANICAL SPECIFICATIONS:**

ITEM	NORMAL DIMENSION
Module Dimension	27.30*27.30*2.37
Active Area	21.74*10.86
Pixel Size	0.148*0.148
Pixel Pitch	0.17*0.17

**ABSOLUTE MAXIMUM RATING:**

PARAMETER	SYMBOL	MIN	MAX	UNIT
Supply voltage for logic	VCC	1.65	5.5	V
Operating temperature	TOP	-40	+80	°C
Storage temperature	TSTG	-40	+80	°C

**ELECTRONICAL CHARACTERISTICS:**

ITEM	SYMBOL	CONDITION	MIN	TYP	MAX	UNIT
Supply voltage for logic	VCC	-----	2.8	3.3	5.2	V
Input high voltage	VIH	-----	0.8*VCC	-----	VCC	V
Input low voltage	VIL	-----	0	-----	0.2*VCC	V
Output high voltage	VOH	-----	0.9*VCC	-----	VCC	V
Output low voltage	VOL	-----	0	-----	0.1*VCC	V
50%check board operating current	ICC	VCC=3.3	-----	12.0	20.0	mA

**CONNECTION DIAGRAM OF ARDUINO UNO TO 4 PIN 0.96 INCH I2C OLED DISPLAY TO ARDUINO UNO:**

**Arduino Uno OLED Wiring**

The image below shows how to connect the 0.96inch OLED I2C display to Arduino. Pin connections are as follows for wiring the OLED display to an Arduino Uno.

- OLED GND – Arduino GND
- OLED VCC – Arduino 5V
- OLED SCL – Arduino Uno A5
- OLED SDA – Arduino Uno A4

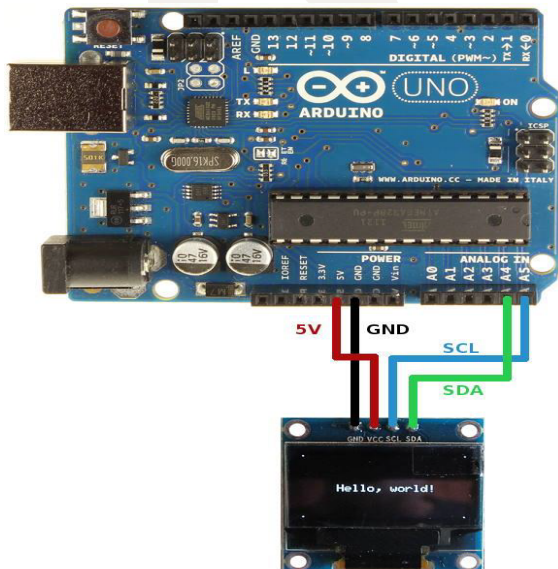

**OUTER DIMENSION:**

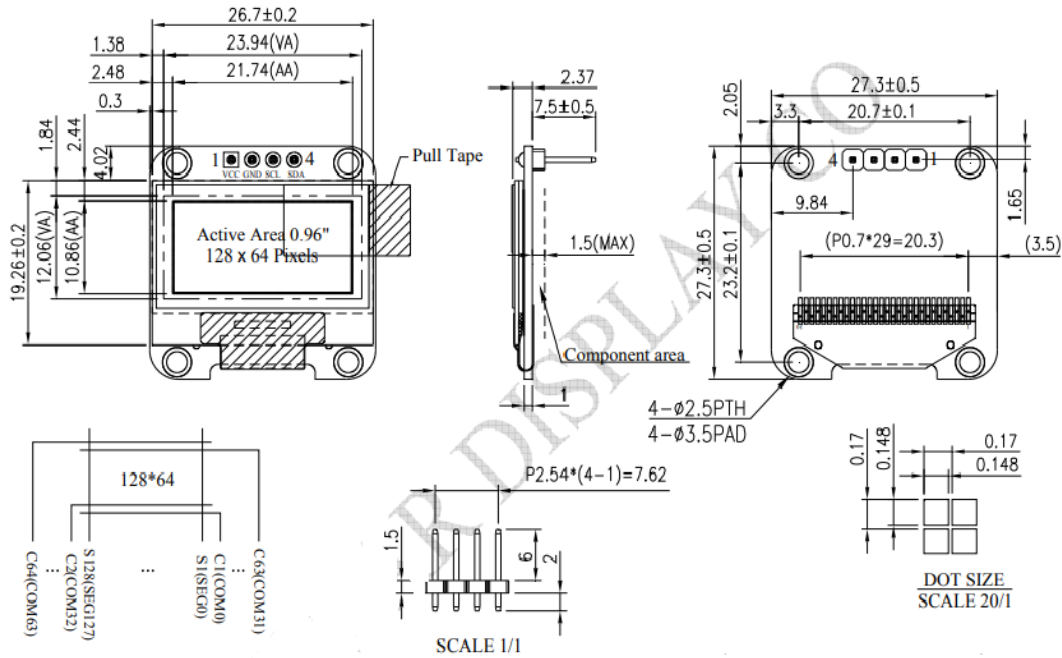

**APPLICATIONS:**

Due to its capability in displaying, it is often used in various application for instances, smart watch, MP3, function cellphone, portable health device and many others.