



This 8 Channel 5V Relay Module with Optocoupler meet the safety standard as control areas and load area have the isolation groove. Optical coupling isolation module.

The triggering of 8 Channel Relay Module is reliable, more stable. The double FR4 circuit board design, high-end SMT process. It has power and relay operation instructions. Relays terminals (C, NC, NO) are accessible through screw terminals which makes wiring up the board very easy. The inputs of the 8 Channel 5V Relay Module are isolated to protect any delicate control circuitry.

A wide range of microcontrollers such as Arduino, AVR, PIC, ARM and so on can control it. The use of such high-voltage relay eliminates the risk of heating up of the relay as electromechanical relay limit the current consumption in accordance with a voltage rating.

Features:

- It can control both AC and DC appliances such as Solenoids, Motors, lights, fans, etc.
- High-quality screw terminals (Terminal Block) provided (C, NC, NO) for quick and easy connection
- Freewheeling diode to protect your microcontroller
- Input Signal Pin connected to Burg stick for easy accessibility
- LED Status indicators to indicate the relay ON/OFF status
- Mounting holes provided
- Signal input with a low-level signal, the common and often start conduction
- The relay can directly control all kinds of equipment and load

Specifications:

Channel	8
Operating Voltage (VDC)	5
Trigger Voltage (VDC)	5
Switching Voltage (VAC)	250@10A
Switching Voltage (VDC)	30@10A
PCB hole diameter (mm)	3.1
Dimensions (Length* Width *Height)	140*57*18 mm

Pin Description:

C=common: This is the commonly terminal. This terminal will be connected to either of other 2 terminals (NO or NC) based on the state of relay.

NO=normally open: As the name indicates this is normally open terminal, i.e. if the relay is not energized (not ON), this pin will be open. We can say that the switch is OFF by default and when the relay is energized it will become ON.

NC=normally close: As the name indicates it is normally closed terminal, i.e. if the relay is not energized (not ON), this pin will be closed. We can say that the switch is ON by default and when the relay is energized it will become OFF.

How to work:

The eight-channel can be used to switch multiple loads at the same time since there are eight relays on the same module. This is useful in creating a central hub from where multiple remote loads can be powered, which is useful for tasks like home automation where the module can be placed in the main switchboard and can be connected to loads in other parts of the house and can be controlled from a central location using a microcontroller.

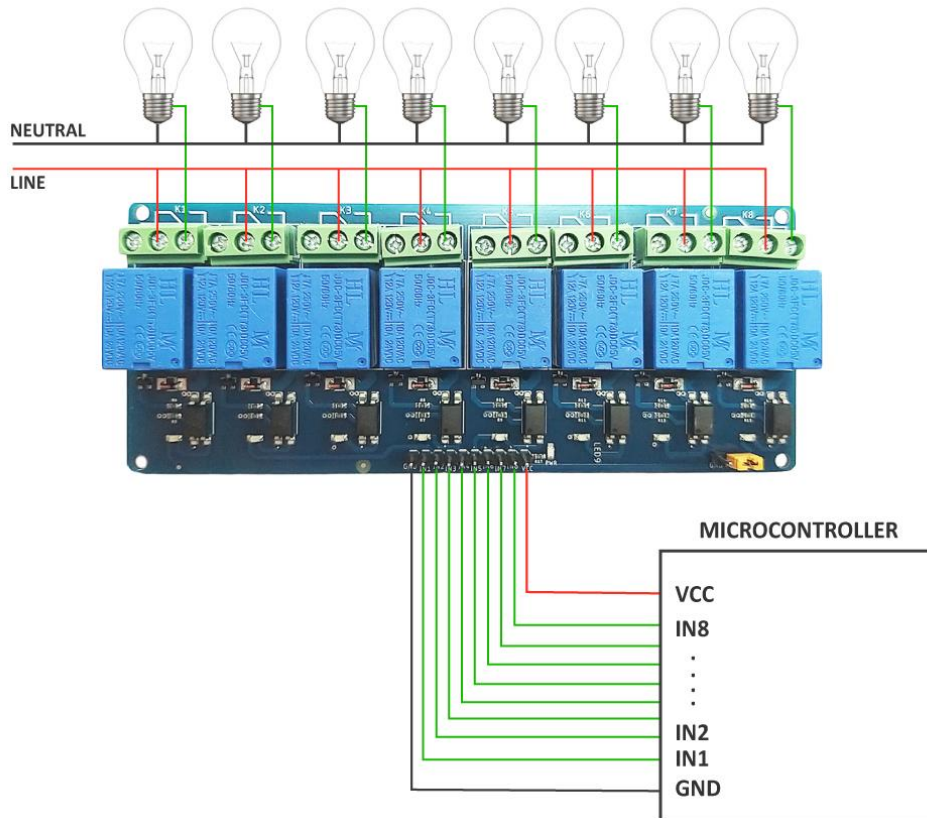

In this diagram, eight separate loads (represented by lightbulbs) have been connected to the NO terminals of the relay. The live wire has been connected to the common terminal of each relay. When the relays are activated, the load is connected to the live wire and is powered. This setup can be reversed by connecting the load to the NC terminal, which will keep it powered on till the relay is activated.

Eight-Channel Relay Module Basic Troubleshooting:

If either of the relays does not turn on:

1. The contacts might be welded due to overcurrent/arcing. Shaking the module firmly might help unstick the contacts.
2. The driver circuitry might have been damaged due to overvoltage.
3. Input polarity might be incorrect.
4. Jumper might not have been moved to the correct position

Application:

- To Control solenoids
- Motors
- Bulbs and bulbs
- Lamps
- Smart home control

