

ESP8266 ESP-32D Wroom Wifi Module



ESP32-WROOM-32D is powerful, generic Wi-Fi+BT+BLE MCU module that target a wide variety of applications, ranging from low-power sensor networks to the most demanding tasks, such as voice encoding, music streaming and MP3 decoding.

FEATURES:

- Core: ESP32-D0WD
- SPI flash: 32 Mbits, 3.3 V
- Crystal: 40 MHz
- Antenna: onboard antenna
- Dimensions (Unit: mm): $(18.00 \pm 0.10) \times (25.50 \pm 0.10) \times (3.10 \pm 0.10)$

SPECIFICATIONS:

Categories	Items	Specifications
Certification	RF Certification	FCC/CE-RED/IC/TELEC/KCC/SRRC/NCC
	Wi-Fi Certification	Wi-Fi Alliance
	Bluetooth certification	BQB
	Green Certification	REACH/RoHS
Test	Reliability	HTOL/HTSL/uHAST/TCT/ESD
Wi-Fi	Protocols	802.11 b/g/n (802.11n up to 150 Mbps) A-MPDU and A-MSDU aggregation and 0.4 μ s guard interval support
	Frequency range	2.4 GHz ~ 2.5 GHz
Bluetooth	Protocols	Bluetooth v4.2 BR/EDR and BLE specification
	Radio	NZIF receiver with -97 dBm sensitivity Class-1, class-2 and class-3 transmitter AFH
	Audio	CVSD and SBC
	Module interfaces	SD card, UART, SPI, SDIO, I2C, LED PWM, Motor PWM, I2S, IR, pulse counter, GPIO, capacitive touch sensor, ADC, DAC
Hardware	On-chip sensor	Hall sensor
	Integrated crystal	40 MHz crystal
	Integrated SPI flash 1	4 MB
	Operating voltage/Power supply	3.0 V ~ 3.6 V
	Operating current	Average: 80 mA
	Minimum current delivered by power supply	500 mA
	Recommended operating temperature range 2	-40 °C ~ +85 °C
	Moisture sensitivity level (MSL)	Level 3

SCHEMATIC DIAGRAM:

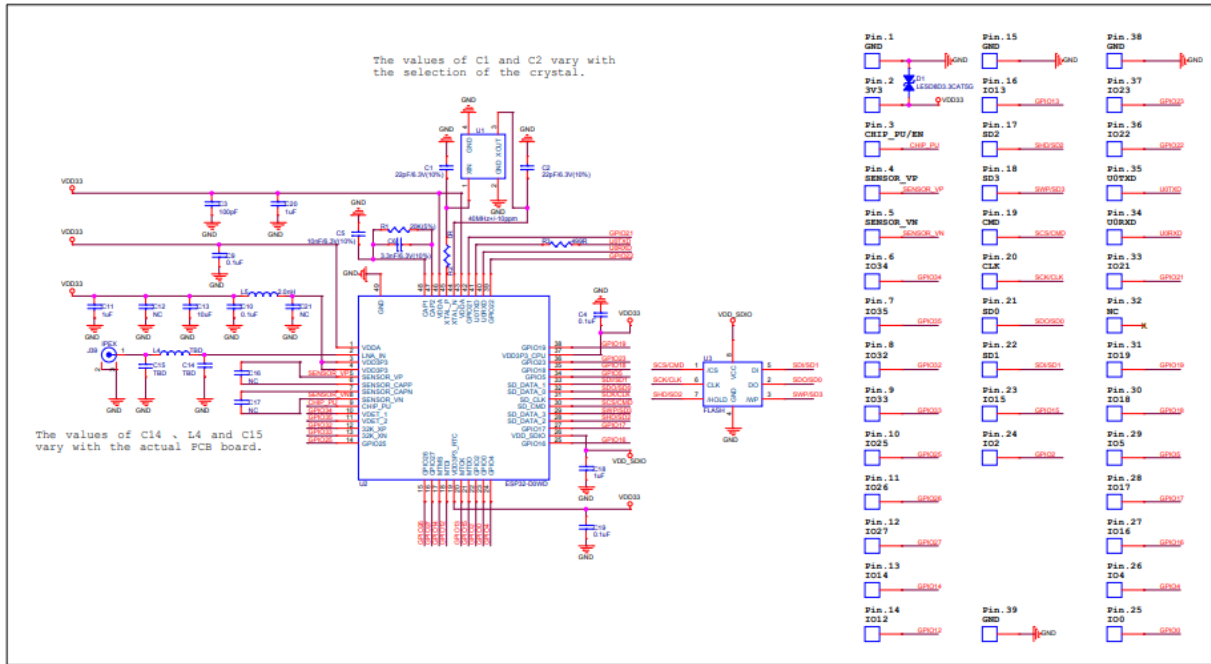

FUNCTIONAL DESCRIPTION:

CPU and Internal Memory:

ESP32-D0WDQ6 contains two low-power Xtensa® 32-bit LX6 microprocessors. The internal memory includes:

- 448 KB of ROM for booting and core functions.
- 520 KB (8 KB RTC FAST Memory included) of on-chip SRAM for data and instruction.
 - 8 KB of SRAM in RTC, which is called RTC FAST Memory and can be used for data storage; it is accessed by the main CPU during RTC Boot from the Deep-sleep mode.
- 8 KB of SRAM in RTC, which is called RTC SLOW Memory and can be accessed by the co-processor during the Deep-sleep mode.
- 1 kbit of eFuse, of which 256 bits are used for the system (MAC address and chip configuration) and the remaining 768 bits are reserved for customer applications, including Flash-Encryption and Chip-ID

External Flash and SRAM:

ESP32 supports up to four 16-MB of external QSPI flash and SRAM with hardware encryption based on AES to protect developers' programs and data.

ESP32 can access the external QSPI flash and SRAM through high-speed caches.

- Up to 16 MB of external flash are memory-mapped onto the CPU code space, supporting 8, 16 and 32-bit access. Code execution is supported.
- Up to 8 MB of external flash/SRAM are memory-mapped onto the CPU data space, supporting 8, 16 and 32-bit access. Data-read is supported on the flash and SRAM. Data-write is supported on the SRAM.

ESP-WROOM-32 integrates 4 MB of external SPI flash. The 4-MB SPI flash can be memory-mapped onto the CPU code space, supporting 8, 16 and 32-bit access. Code execution is supported. The integrated SPI flash is connected to GPIO6, GPIO7, GPIO8, GPIO9, GPIO10 and GPIO11. These six pins cannot be used as regular GPIO.

Crystal Oscillators:

The ESP32 Wi-Fi/BT firmware can only support 40 MHz crystal oscillator

RTC and Low-Power Management:

With the use of advanced power management technologies, ESP32 can switch between different power modes

- Power modes
 - Active mode: The chip radio is powered on. The chip can receive, transmit, or listen.
 - Modem-sleep mode: The CPU is operational and the clock is configurable. The Wi-Fi/Bluetooth baseband and radio are disabled.
 - Light-sleep mode: The CPU is paused. The RTC memory and RTC peripherals, as well as the ULP co-processor are running. Any wake-up events (MAC, host, RTC timer, or external interrupts) will wake up the chip.
 - Deep-sleep mode: Only the RTC memory and RTC peripherals are powered on. Wi-Fi and Bluetooth connection data are stored in the RTC memory. The ULP co-processor can work.
 - Hibernation mode: The internal 8-MHz oscillator and ULP co-processor are disabled. The RTC

recovery memory is powered down. Only one RTC timer on the slow clock and some RTC GPIOs are active.

The RTC timer or the RTC GPIOs can wake up the chip from the Hibernation mode.

• Sleep Patterns

– Association sleep pattern: The power mode switches between the Active mode, Modem- and Light sleep mode during this sleep pattern. The CPU, Wi-Fi, Bluetooth, and radio are woken up at predetermined intervals to keep Wi-Fi/BT connections alive.

– ULP sensor-monitored pattern: The main CPU is in the Deep-sleep mode. The ULP co-processor takes sensor measurements and wakes up the main system, based on the data collected from sensors.

Table 5: Functionalities Depending on the Power Modes

Power mode	Active	Modem-sleep	Light-sleep	Deep-sleep	Hibernation
Sleep pattern	Association sleep pattern			ULP sensor-monitored pattern	-
CPU	ON	ON	PAUSE	OFF	OFF
Wi-Fi/BT baseband and radio	ON	OFF	OFF	OFF	OFF
RTC memory and RTC peripherals	ON	ON	ON	ON	OFF
ULP co-processor	ON	ON	ON	ON/OFF	OFF

PIN FUNCTION:

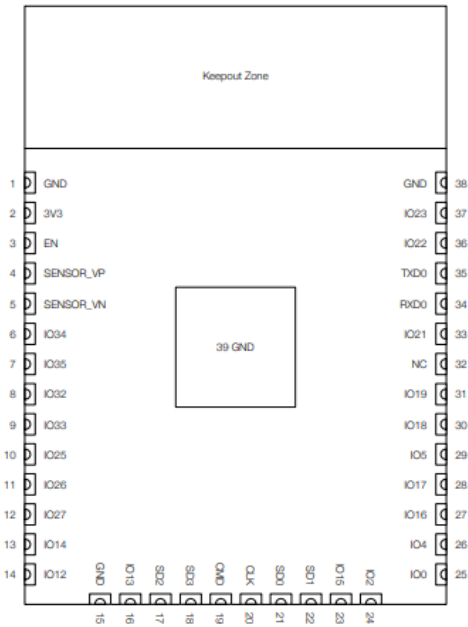

Pin Name	Pin No	Type	Function
GND	1	P	Ground
3V3	2	P	Power supply
EN	3	I	Chip-enable signal. Active high.
SENSOR_VP	4	I	GPIO36, SENSOR_VP, ADC_H, ADC1_CH0, RTC_GPIO0
SENSOR_VN	5	I	GPIO39, SENSOR_VN, ADC1_CH3, ADC_H, RTC_GPIO3
IO34	6	I	GPIO34, ADC1_CH6, RTC_GPIO4
IO35	7	I	GPIO35, ADC1_CH7, RTC_GPIO5
IO32	8	I/O	GPIO32, XTAL_32K_P (32.768 kHz crystal oscillator input), ADC1_CH4, TOUCH9, RTC_GPIO9
IO33	9	I/O	GPIO33, XTAL_32K_N (32.768 kHz crystal oscillator output), ADC1_CH5, TOUCH8, RTC_GPIO8
IO25	10	I/O	GPIO25, DAC_1, ADC2_CH8, RTC_GPIO6, EMAC_RXD0
IO26	11	I/O	GPIO26, DAC_2, ADC2_CH9, RTC_GPIO7, EMAC_RXD1
IO27	12	I/O	GPIO27, ADC2_CH7, TOUCH7, RTC_GPIO17, EMAC_RX_DV
IO14	13	I/O	GPIO14, ADC2_CH6, TOUCH6, RTC_GPIO16, MTMS, HSPICLK, HS2_CLK, SD_CLK, EMAC_TXD2
IO12	14	I/O	GPIO12, ADC2_CH5, TOUCH5, RTC_GPIO15, MTDI,

			HSPIQ, HS2_DATA2, SD_DATA2, EMAC_TXD3
GND	15	P	Ground
IO13	16	I/O	GPIO13, ADC2_CH4, TOUCH4, RTC_GPIO14, MTCK, HSPID, HS2_DATA3, SD_DATA3, EMAC_RX_ER
SHD/SD2*	17	I/O	GPIO9, SD_DATA2, SPIHD, HS1_DATA2, U1RXD
SWP/SD3*	18	I/O	GPIO10, SD_DATA3, SPIWP, HS1_DATA3, U1TXD
SCS/CMD*	19	I/O	GPIO11, SD_CMD, SPICS0, HS1_CMD, U1RTS
SCK/CLK*	20	I/O	GPIO6, SD_CLK, SPICLK, HS1_CLK, U1CTS
SDO/SD0*	21	I/O	GPIO7, SD_DATA0, SPIQ, HS1_DATA0, U2RTS
SDI/SD1*	22	I/O	GPIO8, SD_DATA1, SPID, HS1_DATA1, U2CTS
IO15	23	I/O	GPIO15, ADC2_CH3, TOUCH3, MTDO, HSPICS0, RTC_GPIO13, HS2_CMD, SD_CMD, EMAC_RXD3
IO2	24	I/O	GPIO2, ADC2_CH2, TOUCH2, RTC_GPIO12, HSPIWP, HS2_DATA0, SD_DATA0
IO0	25	I/O	GPIO0, ADC2_CH1, TOUCH1, RTC_GPIO11, CLK_OUT1, EMAC_TX_CLK
IO4	26	I/O	GPIO4, ADC2_CH0, TOUCH0, RTC_GPIO10, HSPIHD, HS2_DATA1, SD_DATA1, EMAC_TX_ER
IO16	27	I/O	GPIO16, HS1_DATA4, U2RXD, EMAC_CLK_OUT
IO17	28	I/O	GPIO17, HS1_DATA5, U2TXD, EMAC_CLK_OUT_180
IO5	29	I/O	GPIO5, VSPICS0, HS1_DATA6, EMAC_RX_CLK
IO18	30	I/O	GPIO18, VSPICLK, HS1_DATA7
IO19	31	I/O	GPIO19, VSPIQ, U0CTS, EMAC_TXD0
NC	32	-	-
IO21	33	I/O	GPIO21, VSPIHD, EMAC_TX_EN
RXD0	34	I/O	GPIO3, U0RXD, CLK_OUT2
TXD0	35	I/O	GPIO1, U0TXD, CLK_OUT3, EMAC_RXD2
IO22	36	I/O	GPIO22, VSPIWP, U0RTS, EMAC_TXD1
IO23	37	I/O	GPIO23, VSPID, HS1_STROBE
GND	38	P	Ground

APPLICATIONS:

- Universal low power IoT sensor hub.
- Home automation.
- Universal low power IoT recorder.
- Mesh network.
- Video streaming of the camera.
- Industrial wireless control.

- OTT TV box / set-top box device.
- Baby monitor.
- Smart Socket.
- Sensor networks.
- Wi-Fi toys: Counters, toys, Anti-lost device.
- Wearable electronic products.
- Wi-Fi speech recognition device.
- Wi-Fi location-aware devices.

DIMENSION:

